

# 400 SERIES

# SOLID VINYL

Elevation View

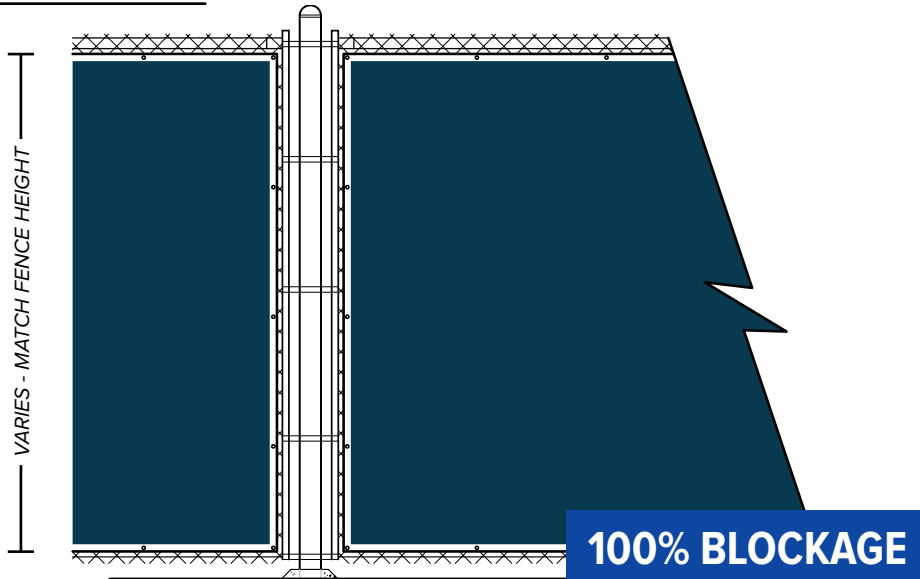

FENCESCREEN PANELS WITH 2" POLYPROPYLENE WEBBING FOR EDGE REINFORCEMENT. 3/8" BRASS GROMMETS AT 24" ON CENTER ATTACH TO FENCE WITH FENCESCREEN FASTENERS OR GALVANIZED HOG RINGS.

Attachment Enlargement

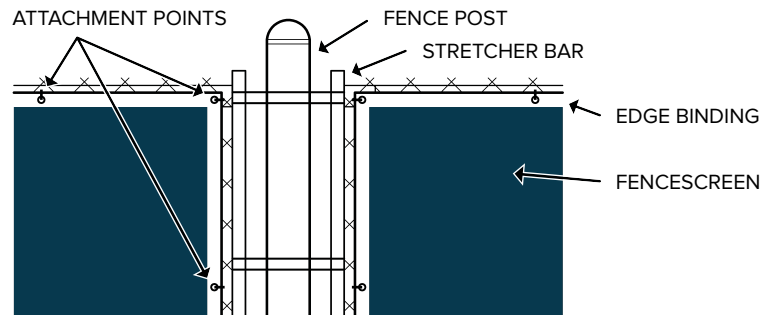

NOTE:  
 • INSTALL PER FENCESCREEN MANUFACTURER RECOMMENDATIONS.  
 • REFER TO STRUCTURAL PLANS FOR ALL FOOTING SIZES.

## FENCESCREEN PROPERTIES

PROPERTIES	TEST METHOD	RESULTS
Weight	ASTM D-5041	13 oz/y <sup>2</sup>
Warp Tensile	ASTM D-5100	238 lbs.
Warp Tear	ASTM D-2261	132 lbs.
Full Tensile	ASTM D-5100	233 lbs.
Full Tear	ASTM D-5512	126 lbs.
Hydrostatic Resist	ASTM D-5512	375 lbs/in
Shade Percentage		100%

### MATERIAL COMPOSITION

Made from solid vinyl (PVC).

### DURABILITY

Solid Vinyl Fence Products are resistant to: severe weather conditions, salt water, sand, road dirt, most acids, alcohol, alkaline, ammonia, petroleum distillates and common environmental pollutants.

### MAINTENANCE

Pressure cleaning of surface contaminants is quickly accomplished with plain water.

### WIND LOAD DISCLAIMER

Fencescreen will not be responsible for fence damage resulting from wind load conditions due to insufficient structural support.

### FEATURES

- UV stabilized to protect against the harmful rays of the sun.
- Available in any custom size.
- 100% Privacy
- Industry leading 3-year limited warranty.

### Available Colors

Green, Black, Brown, Tan, Royal Blue, White, Grey, Red, Navy Blue



*Drawings not to scale.*

**Detail Name:**  
400 Series Solid Vinyl

**Drawing Number:**  
VL400 - VINYL



PHONE: 1.888.313.6313

| [www.FenceScreen.com](http://www.FenceScreen.com)