

ELEVATION VIEW

FENCESCREEN PANELS WITH 2" FOLDED AND WELDED EDGES FOR REINFORCEMENT.  
ATTACH TO FENCE WITH FENCESCREEN ATTACHMENT TIES OR GALV. HOG RINGS.

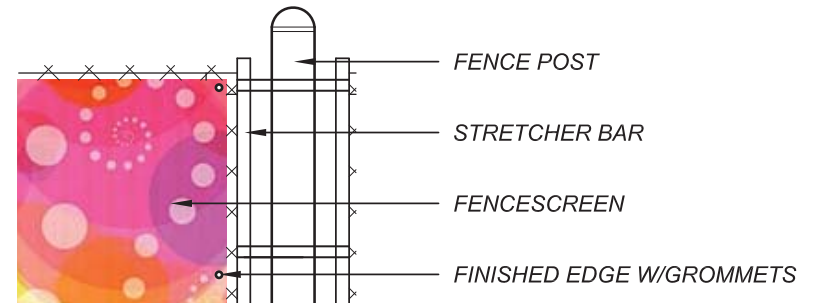

ATTACHMENT DETAIL 3-D



ATTACHMENT ENLARGEMENT

### FENCESCREEN SPECIFICATIONS

#### MATERIAL COMPOSITION: PVC/POLYESTER

PROPERTIES	TEST METHOD	RESULTS
BREAKING STRENGTH	ASTM D757 GRAB	160W X 120F
WEIGHT		8.0 OZ. YD <sup>2</sup>
1" STRIP TENSIL STRENGTH (LBS)	ASTM D751B	100W X 55F
PUNCTURE RESISTANT (LBS)	ASTM D751	230
FLAME RESISTANT	NFPA-701	AF=2 SEC, CHORE 17 ID
INK ADHESION		EXCELLENT
SHADE PERCENTAGE		75%

#### NOTE:

- FENCESCREEN PANELS HAVE FINISHED EDGES FOR MAXIMUM STRENGTH. 3/8" GROMMETS @ 24" O.C. ALL 4 SIDES OF MATERIAL.
- INSTALL PER FENCESCREEN MANUFACTURER RECOMMENDATIONS.
- REFER TO CUSTOMER DESIGN FOR COLORS, HEIGHT AND LENGTHS.



#### AVAILABLE COLORS:

Custom Printed CMYK Color Range on White Base Material

DRAWINGS NOT TO SCALE

DETAIL NAME:

**CUSTOM PRINTED FLEX MESH  
311 SERIES**



DRAWING # **311 CUSTOM FLEX MESH**

**PHONE: 1.888.313.6313**  
**WWW.FENCESCREEN.COM**